

## Kevin's Quick Guide to Throws

<u>SHOT PUT</u>			
<u>Women</u>		<u>Men</u>	
9 to 11	2 kg.	9 to 11	2 kg.
12 to 15	3 kg	12 to 13	3 kg.
16 to 49	4 kg	14 to 15	4 kg.
50 +	3 kg	16 to 17	5 kg.
		18 to 19	6 kg.
		20 to 49	7.26 kg
		50 to 59	6 kg.
		60 to 69	5 kg.
		70 Plus	4 kg.

<u>HAMMER</u>			
<u>Women</u>		<u>Men</u>	
12 to 15	3 kg.	12 to 13	3 kg
16 to 49	4 kg.	14 to 15	4 kg
50 +	3 kg.	16 to 17	5 kg.
		18 to 19	6 kg.
		20 to 49	7.26 kg
		50 to 59	6 kg
		60 to 69	5 kg
		70 +	4 kg

<u>JAVELIN</u>			
<u>Women</u>		<u>Men</u>	
10 to 13	400 gr.	10 to 11	400 gr.
14 to 49	600 gr.	12 to 15	600 gr.
50 to 59	500 gr.	16 to 17	700 gr.
60 +	400 gr	18 to 49	800 gr
		50 to 59	700 gr.
		60 to 69	600 gr.
		70 to 79	500 gr.
		80 +	400 gr.

<u>DISCUS</u>			
<u>Women</u>		<u>Men</u>	
10 to 13	750 g	10 to 11	750 g.
14 +	1 kg	12 to 15	1 kg
		16 to 17	1.5 kg
		18 to 19	1.75kg
		20 to 49	2 kg
		50 to 59	1.5 kg
		60 +	1 kg

### Laying out the Throws Sectors (Landing Areas): see Rule 187.10---187.12

For Shot, Hammer, and Discus, measure 20M out from the center of the circle on both sector lines and 12M across at the 20M mark. You may "center up" using an additional tape. For Javelin, measure out 40M from the 8M mark, through the corner of the runway and 20M across.

Sectors for Shot, Hammer, and Discus

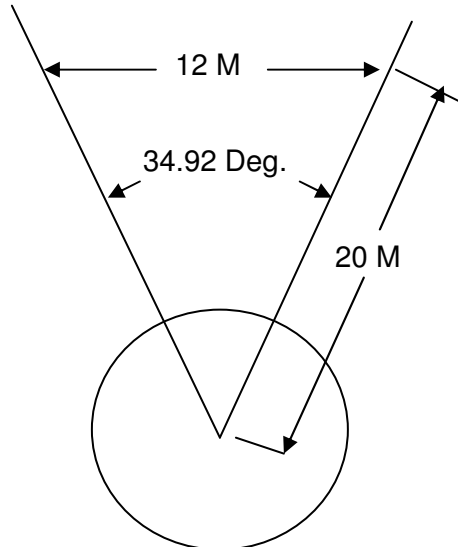

**Inside Dia. For Circle:**  
 Shot 2.135. Hammer: 2.135.  
 Discus: 2.50

Sectors for Javelin

